

LAB INSTRUMENT REFERENCE EEC180A

Purpose: This document provides an introduction to the lab instruments found in the EEC180A lab. These instruments include the HP 54600B oscilloscope, the HP 6205B dual power supply, the HP 6237B triple output power supply, and the HP 3312A function generator. The goal of this reference tutorial is to introduce the basic function and operating procedures for these instruments to students with little lab experience. For more detailed operating instructions, the manufacturer's operating manuals should be consulted.

I. The HP 54600B Oscilloscope

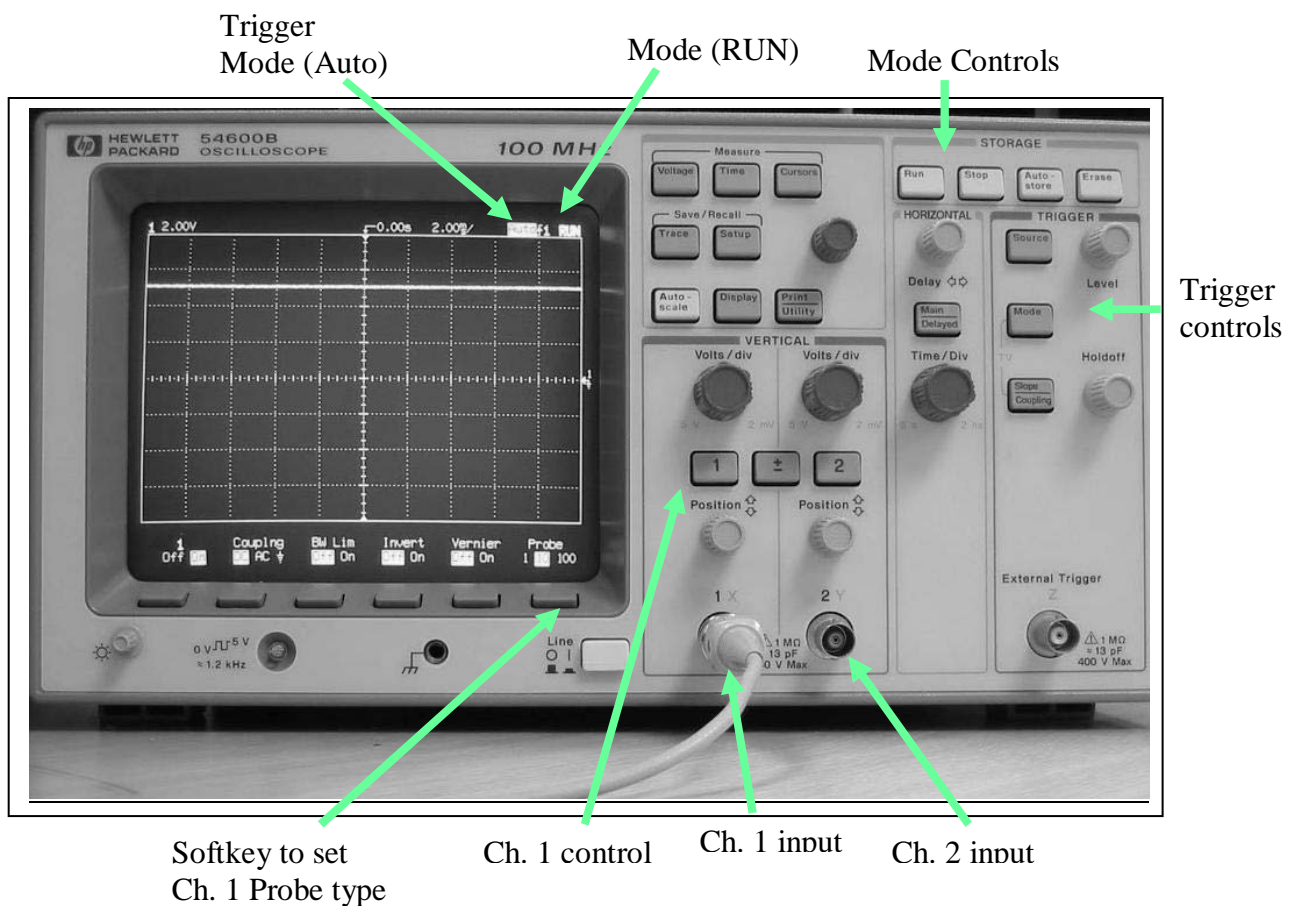

Figure 1. Measuring a DC voltage with the HP 54600B oscilloscope

The 54600B oscilloscope has many different features and functions. We will only introduce a few of the most basic uses of this oscilloscope. The 54600B oscilloscope has two input channels which can be used for measuring signals. In Figure 1, a 10X probe is used to connect a DC voltage to channel 1. In order for the voltage scale, which is measured along the vertical axis, to be accurate, you must set the probe type. To set the

probe type for channel 1, press the “1” button, which is just below the Volts/div knob for channel 1. Next, check that the correct probe type is highlighted under the Probe setting on the screen. If the probe type is not set correctly, use the soft-key just below the Probe heading to toggle the selection to the correct choice. Figure 1 shows that the Probe type has been correctly set to 10.

Measuring a DC signal

Figure 1 shows the measurement of a +5V DC signal. Notice that the ground reference for channel 1 is set to center-line of the grid. (The channel 1 ground reference level can be adjusted using the Position knob just above the channel 1 input BNC jack.) In the upper-left hand corner of the display, you can see that the scope is set to 2V/div on channel 1. Since the signal trace is 2.5 divisions above the center-line, the DC voltage is $(2.5 \text{ div}) \times (2\text{V/div}) = 5.0\text{V}$. Notice in the upper-right corner that the Trigger MODE is set to Auto and the scope is in RUN mode. To measure a DC signal, the Trigger MODE must be set to Auto or Auto Lvl. To set the Trigger MODE, press the MODE button and then press the soft-key under the desired selection.

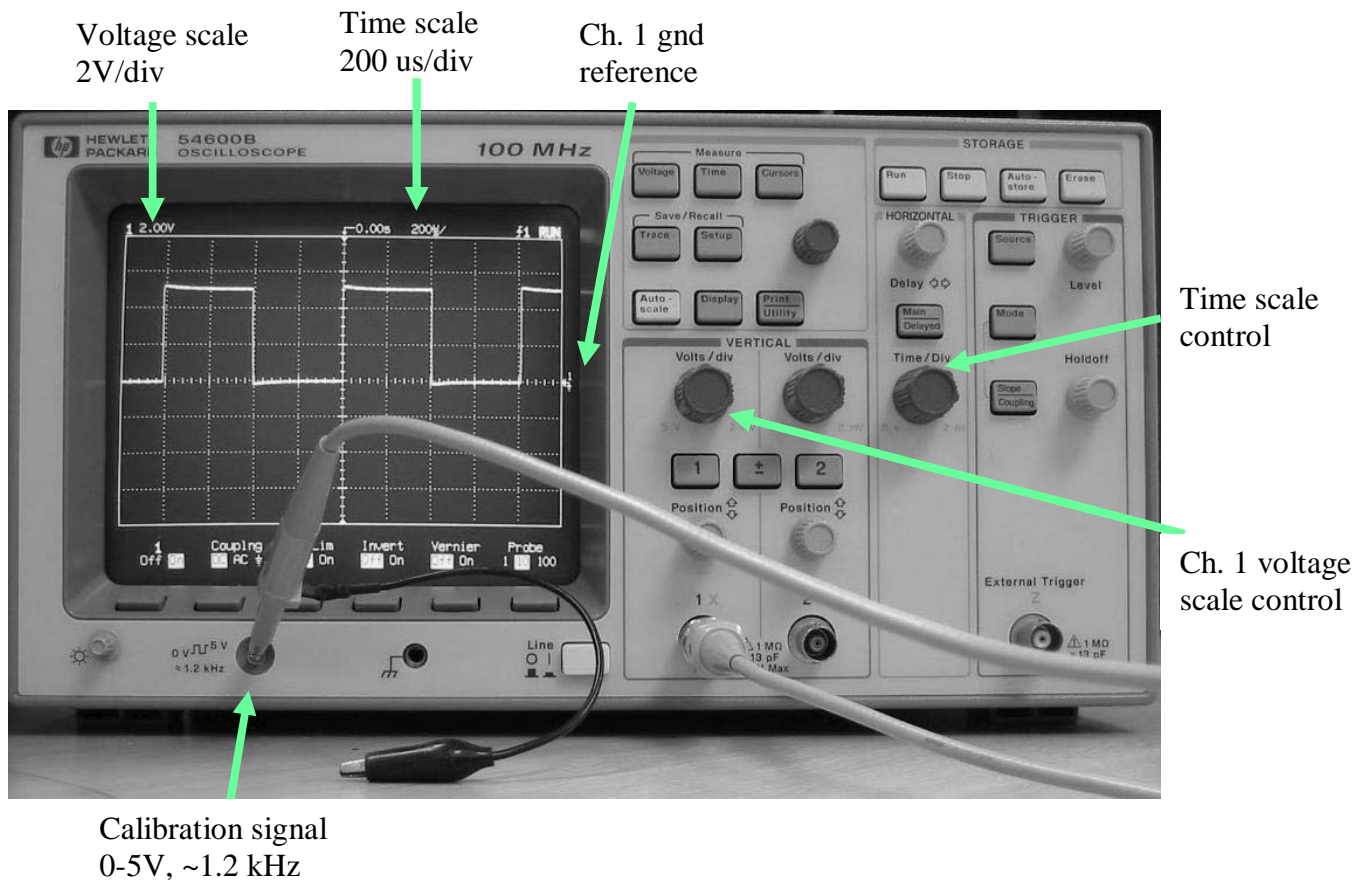

Figure 2. Measuring a square wave with the HP 54600B oscilloscope

Measuring a periodic signal

Figure 2 shows the measurement of the scope’s 0-5V ‘calibration’ signal. The Time/Div knob is used to adjust the scale of the time axis, which is the horizontal axis on the

display. In this example, the Time/Div knob has been set to 200 us/div, as indicated at the top of the display. Since the period of the signal is just slightly over 4 divisions, the period of the signal is about $(200 \text{ us/div}) * (4 \text{ div}) = 800 \text{ us}$ so the frequency is approximately $1/(800 \text{ us}) = 1250 \text{ Hz}$. This measurement agrees with the label on the front panel that indicates that the calibration signal should be $\approx 1.2 \text{ kHz}$. Again, the Trigger Mode should be Auto or Auto Lvl and the mode should be RUN.

The Trigger controls allow you to stabilize periodic waveforms on the screen and capture single-shot waveforms. You use the Trigger controls to select the slope and voltage level of a particular signal used as the trigger signal. When this trigger signal matches the settings, the oscilloscope will trigger a sweep of the cathode-ray tube across the display screen, displaying a single trace of the input signal. Since the trigger occurs on a certain voltage level of either a rising or falling edge, a periodic signal can be displayed as a stationary pattern.

Trigger SOURCE – The oscilloscope does not necessarily have to trigger on the signal being measured, although this is the most common source. The Trigger Source can be channel 1, channel 2 or an External Trigger input signal.

Trigger MODE – The trigger mode determines when the oscilloscope draws a trace. Normal mode: the oscilloscope only sweeps (draws a new trace) when the trigger signal reaches the set trigger point. If the trigger point is not reached, no trace is drawn. Therefore, you would not want to use Normal mode triggering to measure a DC signal because the oscilloscope would never sweep. Auto mode: the oscilloscope “free runs”, meaning that it sweeps even if the trigger point is not reached. This is the mode which should be used for measuring DC signals. Auto Lvl: the oscilloscope resets the trigger level to the center of the signal. Single: the oscilloscope only triggers one single-sweep the first time the trigger point is reached.

Trigger Slope: The slope setting determines if the trigger occurs on a rising or falling edge. In Figure 2, the scope is set to trigger on a rising edge, as shown by the up-arrow at the top-right corner of the display.

Trigger Coupling: Just as an input signal can be AC or DC coupled, the trigger signal can also be AC or DC coupled. (A DC coupled signal retains the DC offset, while an AC coupled signal has the DC component filtered out.) In addition there are special settings for rejecting low frequencies (LF), high frequencies (HF) and rejecting noise.

Trigger Level: This knob adjust the voltage of the trigger point.

Trigger Holdoff: This knob keeps the trigger from re-arming for some amount of time. This can be used to stabilize complex waveforms. The Holdoff range is from 200ns to about 13.5 s. Unless you are trying to measure very complex waveforms, you will probably not need to use this knob

II. The HP 6205B Dual Power Supply

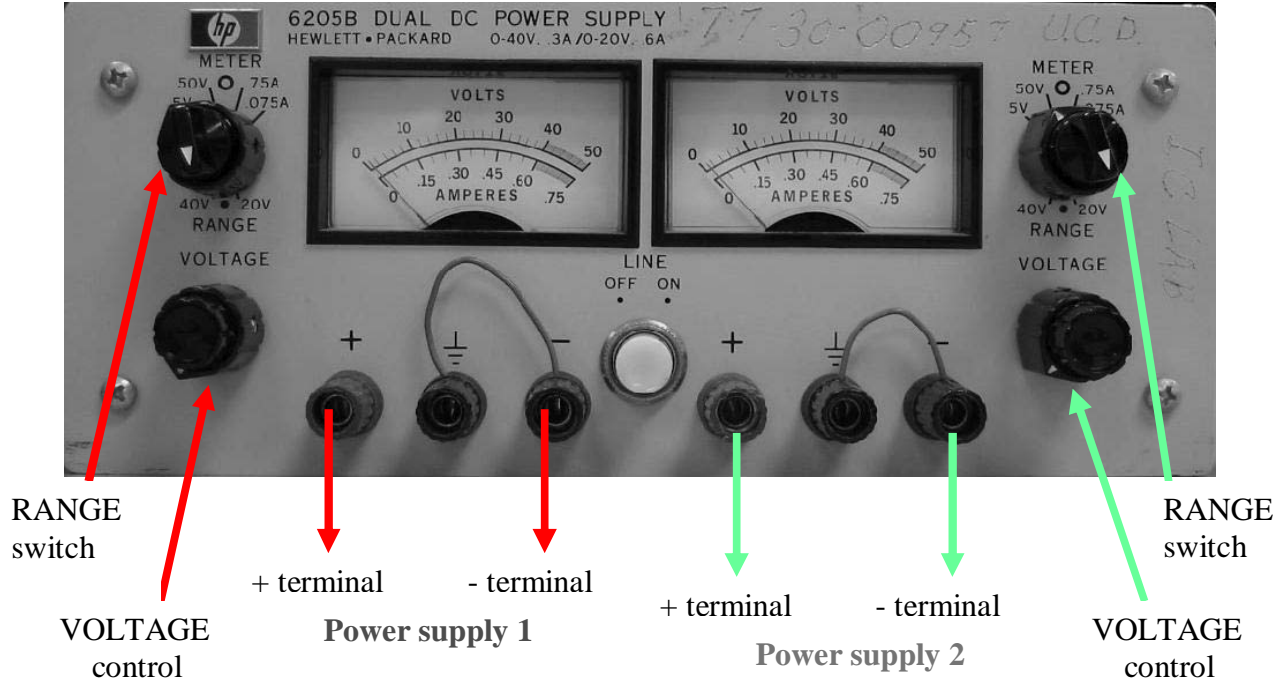

Figure 3. The HP 6205B dual power supply front panel

The HP6205B dual DC power supply consists of two identical, independently-controlled power supplies. Each power supply can provide either 0-40 Volt output at 300 mA or 0-20 Volt at 600 mA, as indicated at the top of the front panel above the meters. The maximum output voltages (40V or 20V) are independently selected using the front panel RANGE switches. Both of the power supplies have separate VOLTAGE controls, which consist of an outer knob for coarse control and an inner knob for fine control.

Both power supplies have their own front panel meter which can be used as either a 0-5V or a 0-50V voltmeter or as a 0-0.75A or a 0-0.075A ammeter. The METER switch has four possible settings, 5V, 50V, 0.75A, and 0.075A, which determine the function of the meter. If the METER switch in the 5V position, the user should read the meter using the VOLTS scale and divide by 10. Thus, when the needle points to 50V, the output is actually measured as 5.0V. When the METER switch is in the 50V position, the VOLTS scale goes from 0 to 50V, as shown on the meter. Note that since the maximum output of the supply is rated at 40V, the region between 40V and 50V, which is shaded on the meter, is outside the range of normal operation. The meters on this power supply will allow you to get an *approximate* DC voltage output. However, since these power supplies are very old and the meters are not well calibrated, the user should always measure the HP6205B power supply output voltage using the oscilloscope before connecting it to his or her circuit. The oscilloscope's reading will be more much accurate than the meter of the HP6205B.

To display the power supply output current on the meter, the METER switch should be set to 0.75A or 0.075A. With the METER switch set to 0.75A, the meter has a range of 0

to 0.75A, which goes beyond the maximum current rating of the power supply (0.6A). In this case, the AMPERES meter can be read directly to get the current value. With the METER switch set to 0.075A, you must divide the AMPERES meter reading by 10. Thus, if the needle pointed to 0.45A with the METER switch set to 0.075A, the output current would be approximately 0.045A. Note that the output current is determined by the load connected to the output terminals and cannot be set using a knob as with the output voltage.

There are three output terminals on the front panel for each of the power supplies. The positive (+) and negative (-) terminals are isolated from the ground terminal, as shown schematically in Figure 4.

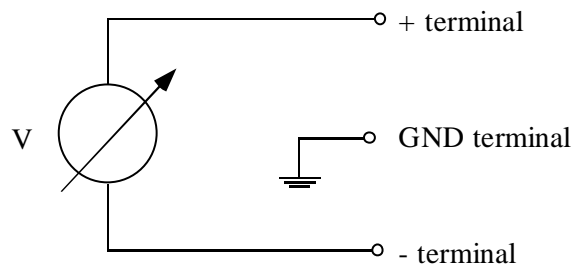

Figure 4. Schematic Representation of HP6205B Terminal Isolation

Either the positive or the negative terminal may be connected to the ground terminal. Notice that in Figure 3, jumper wires have been added to connect the negative and ground terminals. This would enable a user to generate a DC voltage of 5V with respect to ground. If the positive terminal were connected to the ground terminal instead of the negative terminal, then the user could produce negative output voltages with respect to ground at the negative terminal. *One common error that students often make is to connect the “+ terminal” and the “GND terminal” to their circuit when there is no jumper wire connecting the “- terminal” and the “GND terminal.”* From Figure 4, it is evident that such a configuration will not work since there is no closed loop around which current can flow.

III. The HP 6237B Triple Output Power Supply

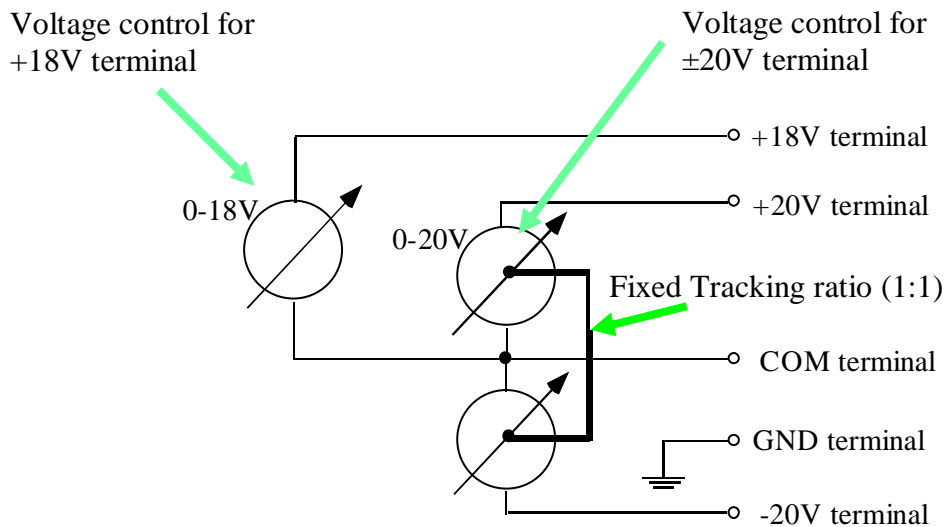

Figure 5. The HP 6237B triple output power supply front panel

Figure 6. Schematic Representation of HP6237B Output Terminals

The HP 6237B triple output power supply consists of a 0 to 18V, 0 to 1A power supply and a 0 to ±20V, 0 to 0.5A power supply with both positive and negative outputs. The 6237B's three outputs share a common output terminal (COM), which is isolated from ground. Thus, any one output terminal can be grounded by connecting a jumper wire to the ground terminal. The most common configuration is shown in Figure 5, where the COM output terminal is grounded using a jumper wire. In this case the 0 to 18V and 0 to ±20V outputs are referenced to ground. If instead, the -20V terminal is grounded, the +20V terminal can supply a 0 to 40V, 0 to 0.5A output.

The output terminals can be represented schematically as shown in Figure 6. As long as the TRACKING RATIO control knob on the front panel is turned fully clockwise to the “FIXED” position, the +20/-20V dual outputs have a fixed 1:1 tracking ratio. This is shown in Figure 6, as a solid bar connecting the voltage sources for the +20V and -20V terminals. For the purposes of this lab, you should always use the dual output supply with the TRACKING RATIO fixed. In order to use a variable tracking ratio (which will not be necessary for EEC180A), you should refer to the manufacturer’s Operating Manual.

As shown in Figure 5, the 6237B has two meters on the front panel – a voltmeter and an ammeter. These meters can be used to measure any of the three outputs, +18V, +20V or -20V, as selected using the METER knob. Note that each meter has two different scales that can be used to read the voltage or current value. *It is important to read the correct scale for the output being displayed on the meter!* For example, if you display the 0 to 18V output, you must read the voltage on the bottom scale. Otherwise, if you use the top scale, you will get an incorrect reading. Students often adjust the 0-18V output to where the needle points to the 5 on the upper voltmeter scale and believe that they have set the output to +5V. In reality, the output will be about +4V because the bottom scale indicates the 0 to 18V output value.

Another common error is to adjust one of the VOLTAGE control knobs (+18V or $\pm 20V$) when the meter is displaying the other output. This can have a serious detrimental effect on a circuit if it is connected to the power supply at the time. A person may turn the VOLTAGE control knob too far before realizing why the meter does not show any change in the output voltage. By that time, the user may have greatly exceeded the desired output level and damaged his or her circuit. *The best procedure is to set the output voltage levels with no load and then verify the output voltages on the oscilloscope before connecting your circuit to the power supply.*

The ammeter is useful for detecting overloads or short-circuits. If the current reading is extremely high, you should immediately shut off the power supply and check all the wiring and connections on your circuit. (This works better than waiting for the circuit to start smoking!)

IV. The HP 3312A Function Generator

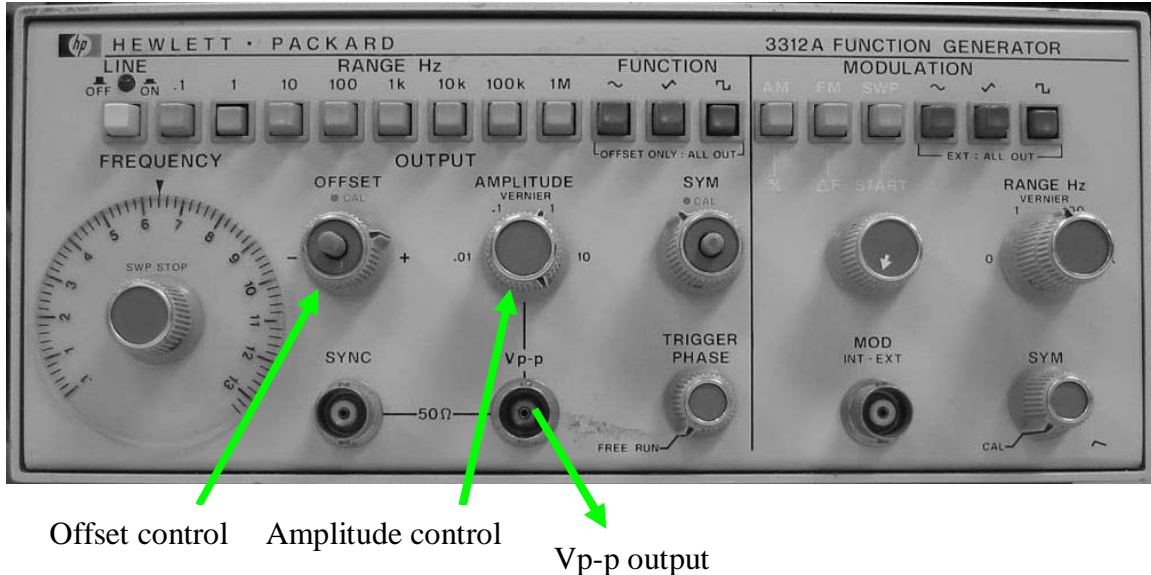

Figure 7. The HP 3312A function generator front panel

The front panel of the HP3312A Function Generator is shown in Figure 7. For the purposes of this lab, we will not discuss the Modulation Generator Operation at all. We will simply describe the Main Generator operation. Thus, you do not need to use any buttons, knob or BNC jack on the MODULATION section, which is to the right of the vertical line.

Using the three FUNCTION buttons, a user can select a sine, triangle or square waveform or, if all three buttons are out, a DC voltage. The signal will appear at the Vp-p BNC output jack. The SYNC BNC output jack will carry a small square-wave signal of the same frequency as the Vp-p output, but not the same waveform or amplitude. The SYNC output can be used as an external trigger for an oscilloscope, but generally you will not need to use this output.

The RANGE Hz buttons and the frequency dial are used to set the output frequency. The frequency dial reading must be multiplied by the RANGE Hz setting to obtain the output signal's approximate frequency.

The AMPLITUDE knob is used to set the output signal peak-to-peak amplitude. With the AMPLITUDE knob (i.e. the outer knob) in the 10 position, the voltage range is from over 10V down to 1V using the VERNIER control (the inner knob). With the AMPLITUDE knob in the 1 position, the output voltage range is from 1V down to 0.1V; in the 0.1V position, the range is from 0.1V to 0.01V and in the 0.01 position from 0.01V to 0V.

The OFFSET knob is used to adjust the DC offset of the output signal. If the blue button in the center of the knob is pressed in, then the DC offset is "calibrated", meaning that it

is fixed at 0V. A signal with a DC offset of 0 will have both positive and negative voltages, which may not be desirable for a digital circuit. To generate a 0 to 5V square wave, which is commonly used for a clock signal in digital circuits, you would need to give the signal a DC offset of 2.5V.

Similarly, the SYM knob is used to adjust the output waveform's symmetry. If the blue button in the center of the SYM knob is pressed in, then the waveform will be symmetric. For example, the square waveform would have a 50% duty cycle (equal duration high and low pulses).

The TRIGGER PHASE knob is beyond the scope of this lab. Therefore, it should be set in the "FREE RUN" position for normal operation. For further information, consult the manufacturer's operating manual.

When adjusting the frequency, amplitude, DC offset and symmetry, you should display the output signal on an oscilloscope. The readings on the 3312A front panel will only give you a rough idea of the characteristics of the output signal. *An oscilloscope should always be used to precisely measure the signal's frequency, amplitude, DC offset and symmetry.*