

LAB 1: INTRODUCTION TO LAB INSTRUMENTS

The purpose of this lab is to introduce the basic lab instruments - digital oscilloscope, power supply and function generator. You will build two very simple circuits and verify their operation.

You should also read the Lab Instrument Reference Guide for an overview and basic operating procedures of the lab instruments you will be using. At the end of this lab, your TA will give you a timed, practical examination on the use of these instruments.

Hardware Required:

1 pc.	74LS04	Hex Inverters
1 pc.	74LS163A	Synchronous 4-bit Binary Counter

Preparation

- Bring a few sheets of graph paper to the lab for making sketches of signals.
- Check the 74LS04 and 74LS163A datasheets on the course web site and record the device pin-outs. Read the general description of each part to get an idea of how it works if you don't already know.
- Read this entire lab write-up. Note that each student will be doing the lab *individually* (i.e. - not with a partner or group) so it is important that you take responsibility for understanding what the lab requires.

I. HP 54600B Oscilloscope

1. Turn on the oscilloscope and allow it to warm up for about a few minutes
2. Attach a cable or 10:1 scope probe to Ch. 1 of the scope. Connect the cable or scope probe to the front-panel probe adjust signal on the oscilloscope. Adjust the voltage and time scales as necessary to display the signal. You should see a 0-to-5 V square wave displayed on the screen. Measure the period of the signal based on the time scale and calculate the frequency of the signal.
3. Press the **1** button to display the configuration settings for Ch. 1 of the scope. Make sure the Probe attenuation factor matches the probe or cable that you are using. For a 10:1 probe, the attenuation factor setting should be 10; otherwise, it should be 1. An incorrect attenuation factor setting will cause your voltage measurements to be off by a factor of 10!

Verify that the front-panel probe adjust signal has a peak-to-peak amplitude of 5V as measured on the scope display.

Also, make sure the Coupling option is set to DC. To toggle through any of the various configuration options, just press the corresponding softkey underneath the option displayed on the screen. (The Coupling option is displayed by pressing the **1** or **2** buttons to display the scope channel configurations.)

4. Measure the period and calculate the frequency of the square wave. You can also use the **Time** button on the front panel to automatically make the measurements.
5. Make a sketch of the waveform shown on the scope display. Label the voltage levels and the time scale. A 10:1 probe can be compensated to eliminate overshoot or undershoot. You will not actually adjust the probe compensation, but you can check to see how well it is compensated. (EGS staff can compensate the probe using a special tool.)

II. Function Generator and Power Supply

1. Connect the Vp-p output of the function generator to Ch. 1 of the scope. Set the function generator to produce a 1 KHz, 0-to-5 V square wave. You will need to adjust the offset, amplitude and frequency knobs. Does the frequency setting on the function generator agree with the value measured on the scope? Record the frequency which you read from the scope and from the function generator and calculate the percentage of error.
2. Connect a power supply output to Ch. 1 of the scope (instead of the function generator output). Set the power supply output to 5V DC. Verify the voltage on the scope. Is the voltage meter of the power supply accurate based on the scope measurement? (Many people read the power supply's voltage meter incorrectly - make sure that you are using the voltage scale which corresponds to the output you are using.)

III. Ring Oscillator circuit

1. Using a 74LS04 IC package, connect five inverter gates in a ring as shown in Figure 1.

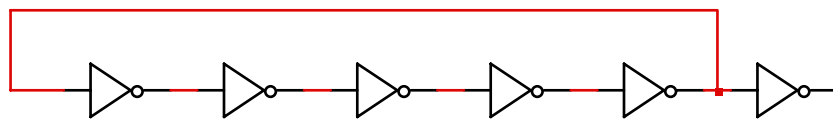

Figure 1 Ring Oscillator

2. Plot neatly the voltage vs. time at the output of any one of the gates in the ring.
3. Measure the period of this waveform. Does it make any difference if you use a 10:1 probe for the measurement rather than a 1x cable? If so, try to explain why. Also, if you use a sixth inverter as an output buffer and measure the period at the output of this gate, is there any difference in the period? If so, explain why.
4. Explain the waveform and the period in terms of the number of gates.
5. What happens if a sixth gate is introduced in the ring? Explain.
6. Based on your answer to (4), what is the propagation time for an inverter gate? Why?

IV. Frequency-divider circuit

1. Using a 74LS163 IC package, set up the circuit shown in Figure 2. (The power and ground connections are not shown. You should check the data sheet to determine which pins correspond to power and ground pins if you don't know.)

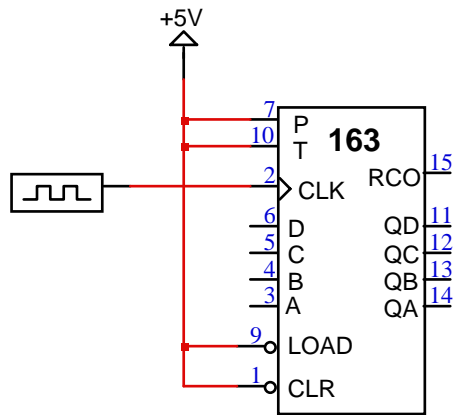

Figure 2. Frequency Divider Circuit

2. Connect the CLK pin to a 0-to-5V square wave signal produced by the function generator. Display the QA signal on the oscilloscope. How does its frequency compare to the CLK frequency? Display the QB, QC, QD and RCO signals on the scope, one by one, and measure the frequency of each one. Record the frequencies and their relationship to the CLK frequency.
3. Display the CLK and QA signals simultaneously on two scope channels. Set the Trigger Source to whichever input signal gives the most stable display. Sketch the waveforms of the two signals on a piece of graph paper.
4. Measure the CLK to QA delay using the cursor buttons on the scope. This delay time is measured from the 50% point of the rising CLK edge to the 50% of the QA transition (falling or rising). Adjust the t1 and t2 cursors to mark the appropriate 50% voltage points and record Δt .
5. Measure the CLK to QB, CLK to QC, and CLK to QD delays and compare them to the CLK to QA measurement. Create a table that shows the 4 delay values. Comment on what the measurements show.

V. Practical examination on instrument usage

The TA will give each student a timed, practical lab examination. This examination will cover basic instrument operating procedures as described in the Lab Instrument Reference tutorial. The examination is pass/fail and may be repeated once if a student fails the first time. The TA will configure the instruments at a lab station in some arbitrary configuration and ask the student to generate signals with specific characteristics. For example, the TA might ask the student to produce some arbitrary DC voltage on either the HP6205B or HP6237B power supplies. Another possible question would be to generate a signal of specific amplitude, DC offset and frequency

using the HP3312A function generator. *Students will not be allowed to use the oscilloscope's AUTOSCALE function key or the Voltage or Time measurement functions.* Instead, students must determine the voltage and period of the signal using the vertical and horizontal grid markings and the adjustable voltage and time scale settings.

Lab Report

Each individual is required to submit a lab report. Use the format specified in the "Lab Report Information" document available on the class web page. Be sure to include the following in your lab report:

- Lab cover sheet with TA verification. (The TA will specify what he/she will verify.)
- Graded pre-lab
- Answers to all questions posed in the lab write-up
- All plots and tables required in the lab write-up

Grading

Prelab	20 points
Lab Checkoff	50 points
Lab Report	30 points