

EEC 118 Spring 2006 Lab #3 Part 2: D Flip-Flops

Dept. of Electrical and Computer Engineering
University of California, Davis

April 12, 2006

Reading: Kang and Leblebici Chapters 5 and 8 [1].

I OBJECTIVE

In this experiment, you will build a dynamic and a static D-type flip-flop out of inverters and transistors. Due to the high threshold voltage of the CD4007 transistors, a 15V power supply is used.

II DYNAMIC MOS FLIP-FLOP

Step 1 Build the circuit in Figure 1 using the pin connections shown (the pin numbers are circled). Use $C=1000$ pF, $V_{DD} = 15V$, and $V_{SS} = 0V$. Be sure to connect pin 14 of the CD4007 to +15V and pin 7 to GND.

Construction tip: A suggested board layout is shown in Figure 2. Place an extra 4007 below the 4049; it will be used in Section III. You will eventually have on your protoboard a 4007, 4049, and 4007, preferably in that order (to simplify wiring). For Section II, use the upper 4007 (U1) and the 4049 (U2) to build the dynamic flip-flop. The lower 4007 (U3) will be used in Section III.

Step 2 (20 points) Verify that the circuit operates as a flip-flop by connecting the D input to the \overline{Q} output. With this connection, the circuit operates as a T flip-flop, and the output of the flip-flop will be the clock divided by 2. Try using a 10 kHz square wave that goes from 0 to 15 V for the clock (CLK). If the circuit does not work as expected, try increasing the clock voltage (why does increasing the voltage help?) until it starts working. Use $C=1000$ pF. Sketch the CLK, \overline{M} , and Q waveforms. At what part of the clock waveform is the D input latched? Increase the CLK frequency to determine the maximum clock frequency for which the T flip-flop operates. (**NOTE:** If your clock generator can only output a 10 V square wave, you can connect the 10 V square wave to the input of a 4049 inverter with $V_{DD} = 15$ V. It should output a 15 V or higher voltage square wave that you can use as the clock. If necessary, increase the DC voltage of the 10 V square wave to improve the symmetry of the output square wave.)

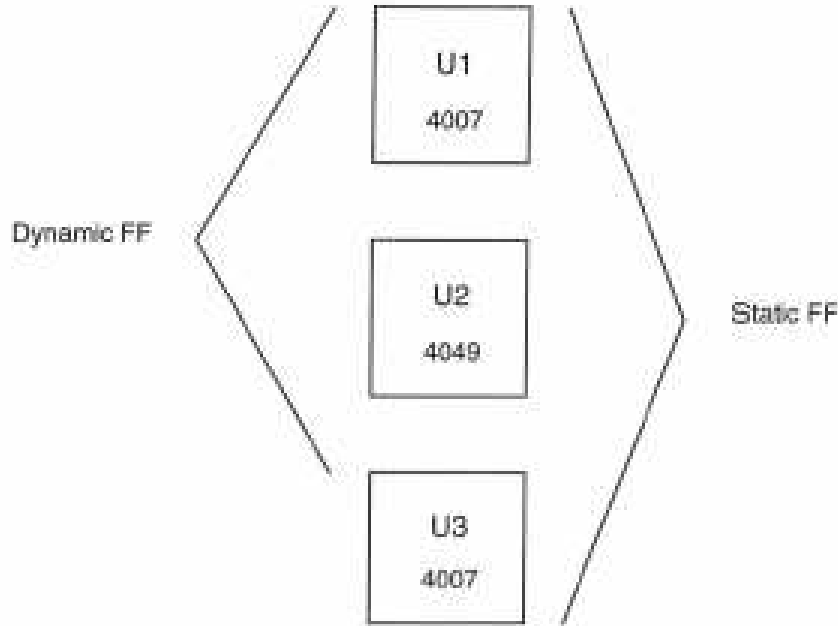

Figure 2: Suggested board layout.

Step 3 (10 points) Tie the D input high (connect it to V_{DD}). Sketch the clock CLK and the waveforms at nodes D , Q , X , and Y . Use the clock as the trigger signal for observing these waveforms. Explain the waveforms and voltage levels.

Step 4 (10 points) Repeat Step 3 with the D input low (connect it to GND).

Step 5 (10 points) With the D input grounded, reduce the clock frequency until you see significant droop in the voltage at node Y . (This clock frequency should be on the order of 1 kHz). Continue to decrease the clock frequency until the droop is large enough to cause 'glitches' in the Q output. Sketch the CLK, Y , and Q waveforms.

Step 6 (10 points) Change C at nodes X and Y from 1000 pF to 100 pF. Record the clock frequency at which significant droop appears at node Y (and glitches appear in the Q output). Repeat this measurement with $C=10$ pF.

III STATIC MOS D FLIP-FLOP

Step 7 Add the extra circuit shown in Figure 3 that will convert the dynamic flip-flop in Figure 1 to a static flip-flop. Use the available inverters in U2. Add U3, another CD4007, and connect its pin 14 to +15 V and pin 7 to GND.

Step 8 (20 points) Verify that the circuit operates as a flip-flop by connecting the D input to the \overline{Q} output to build a T flip-flop. Use a 10 kHz square wave that goes from 0 to 10 V for

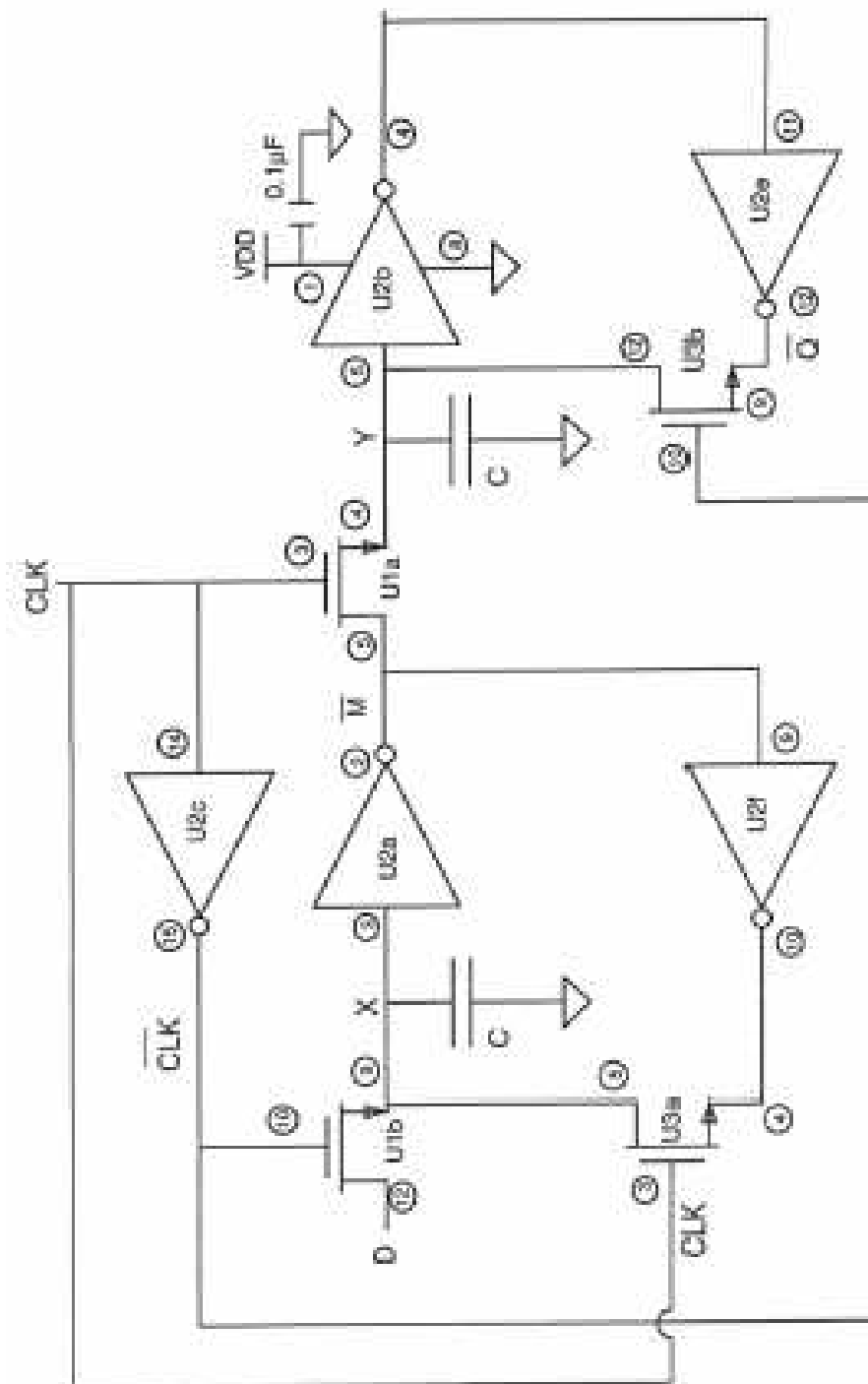

Figure 3: Static MOS D Flip-Flop schematic diagram.

the clock (CLK). If the circuit does not work as expected, try increasing the clock voltage again until it starts working. Use $C=1000$ pF. Sketch the CLK, \overline{M} , and Q waveforms. At what part of the clock waveform is the D input latched? Increase the CLK frequency to determine the maximum CLK frequency for which the T flip-flop operates.

Step 9 (10 points) Tie the D input low. Use $C=1000$ pF. Slow the clock to the same frequency recorded in Step 5 above. Do you see the droop at node Y ? Try a lower frequency. Do you see droop at node Y ? Try $C=10$ pF. Do you see droop at node Y ? Why or why not?

Step 10 (10 points) What are the advantages and disadvantages of the static D flip-flop?

References

- [1] S.-M. Kang and Y. Leblebici, *CMOS Digital Integrated Circuits: Analysis and Design*, 3rd ed. San Francisco: McGraw-Hill, Inc., 2003.