

from G & Tones

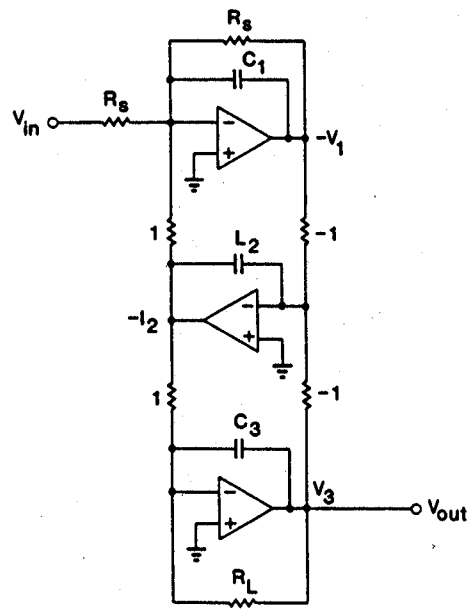

(d)

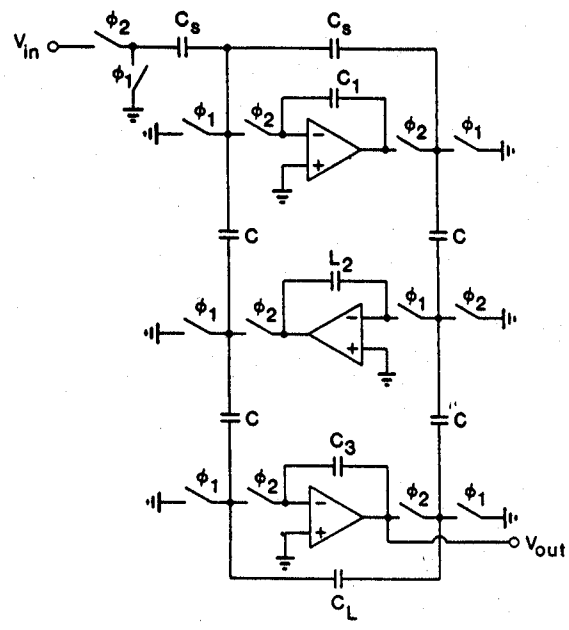

(e)

FIGURE 5.18. continued.