



UNIVERSITY OF CALIFORNIA, DAVIS

Poultry Data Acquisition

EEC 136AB

SENIOR DESIGN FINAL REPORT

MARCH 16, 2016

Prepared By:

Ben Ryan, Ryan Maquiss, Yin Yi Chan

Prepared For:

Professor André Knoesen

Abstract

This senior design group created two primary systems to monitor a chicken coop's ambient environment and the chicken's movement in and out of the coop. Temperature, humidity, and light levels were recorded and stored on an SD card along with the time each chicken entered and exited the coop. This data is useful for keeping track of each chicken in order to notice patterns of when each chicken enters the coop. This can help the owners of the coop from losing the chickens. The temperature, humidity, and light sensors can allow the owners of the coop to monitor the conditions that the chickens are facing over a given period of time.

Contents

1	Introduction	3
2	Background Theory	3
2.1	Environmental Condition Recording	3
2.2	Chicken Movement Tracking	3
3	Design	3
3.0.1	Sensor 1: Temperature and Humidity Sensor	3
3.0.2	Sensor 2: Ambient Light Sensor	4
3.0.3	Sensor 3: RFID Reader	4
3.0.4	Sensor 3: RFID Tags	5
3.0.5	Sensor 4: Infrared Receiver	5
3.0.6	Sensor 5: Infrared Emitter	5
3.0.7	SD Card Reader	6
3.0.8	RJ45/ Ethernet Connectors	6
3.0.9	Board Designs	6
3.0.10	Enclosure	7
3.1	PCB Pictures	8
4	Power Calculations	8
5	Firmware/ Software Design	8
5.1	Micro-controller Firmware	8
5.2	Environmental Monitor Firmware	8
5.3	Chicken Counter Firmware	9
5.4	App Software	9
6	Procedure: Design Verification and Testing Methodology	10
6.1	Environmental Monitor	10
6.2	Chicken Counter	11
7	Final Budget	11
8	Results and Discussion	11
9	Conclusion	12
10	Acknowledgments	13

1 Introduction

On the UC Davis campus, there is a chicken coop used for housing of chickens that lay eggs. With this chicken coop, there are a couple of problems that we plan to address through our electronic systems. The first problem that needs to be addressed is how to best keep track of the chickens as they enter and leave the chicken coop. Chickens are unpredictable in how they move about so it is difficult to predict the patterns with which they go in and out of the chicken coop without a specific tracking scheme in place. Due to this, it is hard to keep track of chickens when they are lost from the coop and do not return. A tracking system would help keep track of how many chickens are in the coop at a given time and if the number of chickens is decreasing over a period of time.

In addition, it is desirable to keep track of certain characteristics of the chicken coop such as the temperature, humidity, and ambient light. It is necessary to keep track of these characteristics in order to make sure the chickens are kept in a climate that is suitable for their living habits.

2 Background Theory

2.1 Environmental Condition Recording

The temperature, humidity, and light readings will be done by two individual sensors all placed on one printed circuit board (PCB). One sensor measures temperature and humidity while the other measures the light. The temperature is recorded in degrees Celsius. The humidity is recorded in percentage of moisture compared to the maximum amount of moisture in the air. The light is measured in lumens. They have their reading recorded on a secured digital storage card (SD card). These values are stored in an easily computer readable form that can be imported into Excel and Matlab for analysis. The current readings from these sensors will also be broadcast over Bluetooth Low Energy (BLE) to any nearby Smartphone that has our custom mobile application.

2.2 Chicken Movement Tracking

The monitoring of the chickens will be done using a three part verification system. The chick-

ens trigger one of two Infrared trip sensors (IR trips) when they break the beam by walking between a emitter and receiver. Then, the Radio Frequency Identification (RFID) tag on their foot will be read by our RFID readers under them. Last, they will trigger a second set of IR trips to verify that they actually walked through the door, and then their unique RFID tag will be recorded with their direction and time that they passed through the door.

Radio Frequency Identification (RFID)

Radio Frequency Identification (RFID) is used to identify and track individuals in many industries. RFID is composed of two parts, a transmitter tag and a receiving reader. The tags are passive (meaning no power supply on them) and are powered by the reader. The reader powers the tags, which in turn provide their ID number. Each number is unique, which makes it very easy to match tags with individuals. In this application, each chicken will have it's own tag, and therefore it's own unique ID number.

RFID Range In industry, tags made to transmit at 125KHz are the standard. For example, a cow will have an ear pierced with a tag that will be read with a hand held reader. These tags are easy to power and relatively inexpensive at the expense of a short read range (approximately 10 cm maximum). This means that our implementation of the tag reading system requires the chickens to be limited in the region with which they can walk through the door. Future designs could consider using a higher frequency reader and tag frequency.

3 Design

3.0.1 Sensor 1: Temperature and Humidity Sensor

This Honeywell humidity sensor(**Figure 1**) was used as one of the two sensors on board the ambient sensor monitor. I2C communication will be easy to set up as the whole team has used it in previous labs, and the package allows for easy soldering. Mouser Part Number: 785-HIH-6030-021-001, \$7.62 for package of one. This sensor is particularly good for our applications for a couple of reasons. First it is cheap. Second, it is also accurate to within 1 degree Celcius at any

given time, which is very good for the applications that we need it for. Its humidity accuracy is also within 4.5 percent, which is good enough for our applications. Overall, this sensor is relatively easy to use, accurate, and cheap. This part operates well between -40 and 100 degrees Celcius, which is good because our application is intended for outdoors, where the temperature varies greatly over the course of a year.



Figure 1: Humidity Sensor

3.0.2 Sensor 2: Ambient Light Sensor

This light sensor was chosen due to its simple nature (**Figure 2**). It is an analog signal, which allows it to be easily read through the ADC on the PSoC and filtered so that it is read most accurately. It is very low cost (\$1.33 for one) and one of the lower power sensors (under 100mW). It has a high sensitivity ($I_{PCE} = 50\mu A(E_V = 100I_X)$) and a high angle of half sensitivity ($\phi = 60^\circ$). The SMD package allows for easy soldering and is quite compact at 4_{mm} by 2_{mm} . The sensor operates as a BJT where the base voltage is applied via the light on the sensor. The more light that hits the sensor, the more current that runs through the collector to the emitter. Using a resistor at the collector, this current can be turned into a voltage that can be read into our PSoC using its analog to digital converter. We used a 10 kilo-ohm resistor as recommended in the data sheet for this purpose. This part operates well between -40 and 100 degrees Celcius, which is good because our application is intended for outdoors, where the temperature

varies greatly over the course of a year.

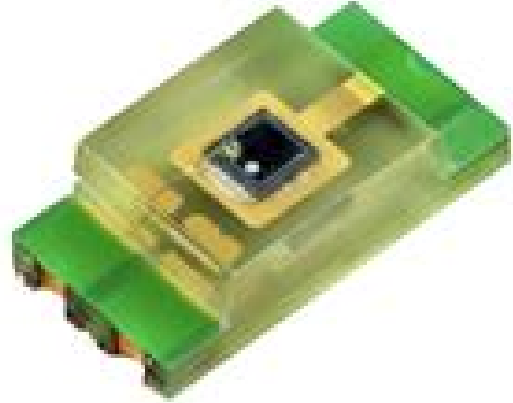

Figure 2: Light Sensor

3.0.3 Sensor 3: RFID Reader

The RFID setup was the most difficult to pick parts for, as the whole team is somewhat new to RFID. We now know that there are two types of low frequency tags, 125 kHz, and 134.2kHz. We chose to use the Sparkfun RFID reader because it was compatible with our 125 kHz tags, specifically meant for chickens (**Figure 3**). It is also easily readable using UART. Many other readers were poorly documented, and hard to use. Our reader provides an automatic UART output to our micro-controller when ever a tag is in a certain proximity of the sensor. The disadvantage of using this sensor was it's range. Although the 125KHz readers are well documented and easy to use, as well as being industry standard, they did not quite meet our ideal read range. In a commercial setting, tags are read using hand scanners at a close proximity, and our project would be better suited to a reader than scanned anything in the vicinity rather than directly in front of it.



Figure 3: RFID Reader

3.0.4 Sensor 3: RFID Tags

EM4305 Tags (**Figure 4**) are the current industry standard, and these tags from RFIDShop are made to be banded onto fowl legs. They are 125KHz and work well with our readers. They easily snap onto the legs of the birds and won't restrict their leg growth in any way, while staying low on their leg to be easily read by the RFID reader. While they suffer a read range problem, that is more due to the communication frequency rather than the tag design itself. The main advantage of these tags is that they are easily pre-made to be placed directly on the legs of the chickens themselves. They conform to the industry standard for both chicken bands and frequency used.



Figure 4: EM4305 RFID Tags

3.0.5 Sensor 4: Infrared Receiver

For our project, we are using a 38 kHz IR receiver to pick up the IR sent out from our IR LEDs (**Figure 5**). In previous groups, IR has proven itself to be a reliable trip sensor. The sensor has a long range, and can use the demodulation of the 38KHz signal to filter lots of IR noise (such as sunlight). This means that it works reliably in any lighting condition well, and at distances from centimeters to feet. In addition, it has a good sensitivity to supply voltage ripple that is useful in case of any errors in the supply. This sensor provides a low output voltage when it is receiving infrared signals and a high output voltage when the infrared beam has been blocked. This makes it perfect for producing an interrupt when a chicken walks through the beam.



Figure 5: IR 38KHz modulated receiver

3.0.6 Sensor 5: Infrared Emitter

For our project we are using an OSRAM IR LED (**Figure 6**) that will be powered by a 38 kHz square wave produced by a clock on our micro controller. This signal makes it easy for the receiver to filter any noise in the IR spectrum. It has a 10 degree angle, meaning that it mostly aims in the direction it is pointing, making it perfect for providing a beam that can be tripped. This LED is also useful for its small package, allowing it to take up less room on the printed circuit board. It operates on a wide range of

temperatures, which is again good for an outdoor applications.



Figure 6: IR Led

3.0.7 SD Card Reader

For our project we are using an SD card connector (**Figure 7**) in order to write our data to a Micro-SD card which can then be opened on a computer. This generates a file for the user to log all of the data. This data can then be stored and looked at outside of the project. We then have a Matlab script that can plot the data found in the file. This SD card reader is easily solder-able as a surface mount component and provides easy write-ability through the SPI communication protocol. The main disadvantage of using an SD card to store data is that it consumes a lot of power. One thing that we could add to a future design would be a separate controllable voltage regulator that could allow the SD card to be more easily turned off because SD cards naturally draw a lot of current.

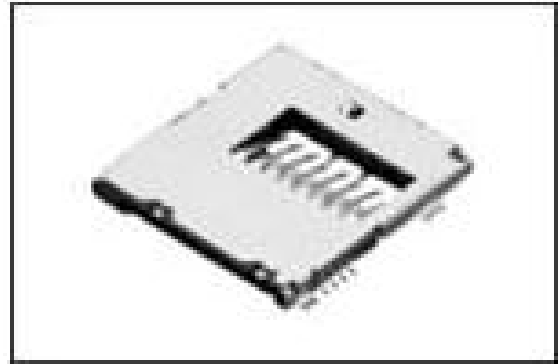

Figure 7: sd card

3.0.8 RJ45/ Ethernet Connectors

For our chicken counter design, we decided to use Ethernet cables in conjunction with RJ45 connectors (**Figure 8**) in order to connect the main board to our Infrared receiver and emitter, as well as our RFID readers. This was due to the fact that each of these devices has to be in a separate location physically. The benefit of Ethernet cables is that they are shielded and are easy to plug in and be interchangeable. They allow signals and power to be routed over distance. In addition, they are easy to use and allow multiple signals to be routed per cable. We added an RJ45 port to each of our receiver, transmitter, and RFID boards so that power, ground, and signals could be routed between motherboard and daughter boards.

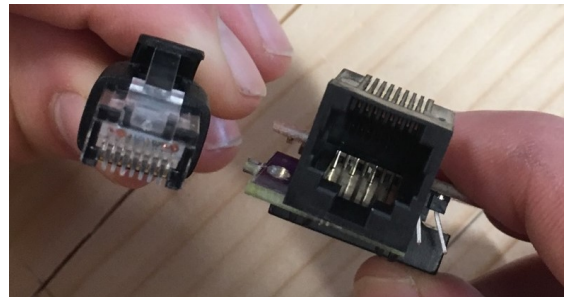

Figure 8: Cat6 Male and Female Connectors

3.0.9 Board Designs

Below, we will show pictures of the boards for our environmental monitor and chicken counter. The environmental board contains a PSoC 4 and a PSoC 5 as well as the temperature/humidity and light sensors. It also contains an SD card for storage. It is powered off of a 3.7 V battery and has a voltage regulator to limit the voltage to all

of the sensors and micro-controllers to 3.3V. Our Chicken counter board also has a PSoC 4 BLE and a PSoC 5 in addition to an SD card component. Aside from that, it has RJ45 connectors that break out to connect to breakouts for the IR receivers, emitters, and RFID readers through Ethernet cables. It is powered through a wall plug to provide 5V to the device.



3.0.10 Enclosure

Figure 9: IR and RFID cases after removal from field test

To enclose the project, we used hard plastic cases that were cut to accommodate our cat6 power and communication lines (**Figure 9**). For the IR trips, a clear top case was used that has mount holes for the PCB. These clear top cases allow the modulated IR signal to pass through the case, but keep a tight seal to keep the board safe. The RFID used a hard black plastic case with squares cut out for the RJ45 jack. This both acted as an access point for power and communications and helped anchor the board inside the casing.

All cases had to be sealed against tampering by chickens, which meant they had to be strong enough to withstand a fairly constant pecking. They also had to be reasonably water proof. The cases themselves provided enough physical protection, but making the cases water proof was a bit harder. For long term deployment, it would be smart to use an epoxy to seal the joints, but it would be difficult to remove the boards again if we wanted to test something. For our short term test deployment, we sealed the joints and connections with outdoor rated electrical tape.

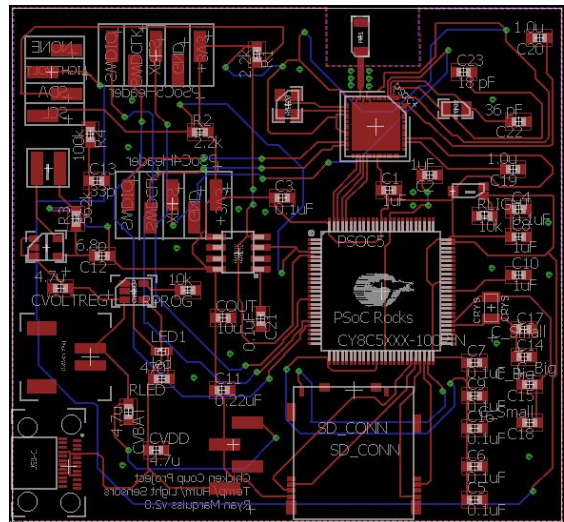

Figure 10: Environmental Monitor

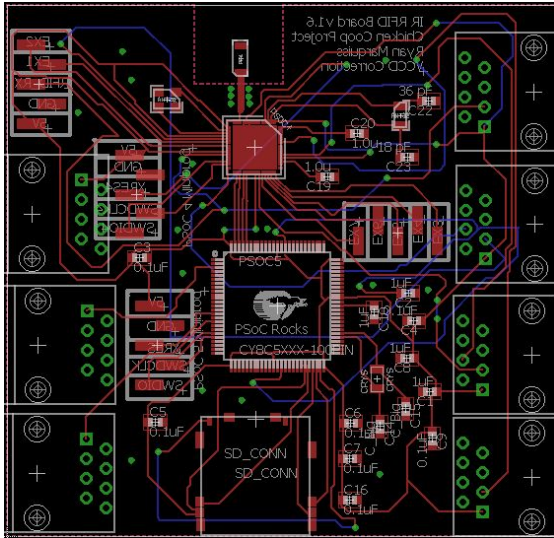

Figure 11: Chicken Counter

3.1 PCB Pictures

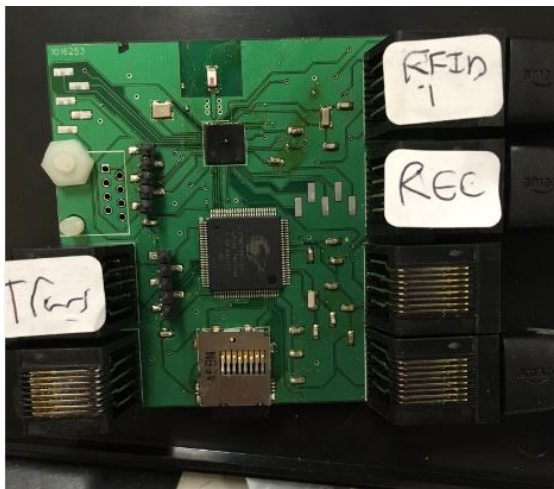

Figure 12: Chicken Counter PCB

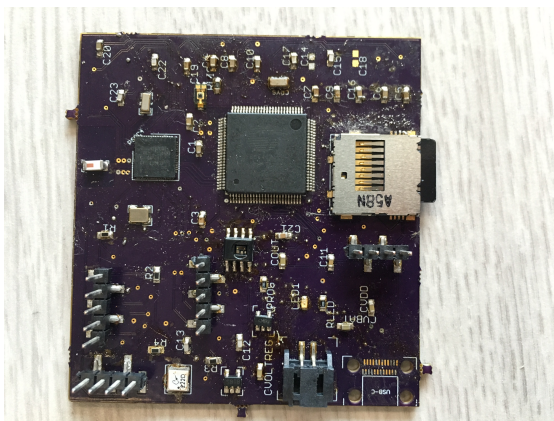

Figure 13: Environmental Monitor PCB

4 Power Calculations

In our table below, we have summarized the power consumption of each of our sensors, as well as the PSoC chip that we will be using in our project.

Sensor	I_{min}	V_{min}	P_{diss}	P_{perday}
Temp/Hum Sens	0.65mA	3.3V	2.15mW	1.03W
Amb Light Sens	20mA	3.3V	100mW	14.4W
IR Emitter	60mA	3.3V	99mW	8553W
IR Sensor	15mA	3.3V	165mW	4.95W
RFID Unit	180mA	5.0V	900mW	1,296W
PSoC 4 (active)	1.7 mA	3.3V	5.61 mW	161 mW
PSoC 5 (active)	3.1 mA	3.3 V	10.23 mW	294.6 mW
PSoC 4 (inactive)	1.3 uA	3.3V	4.29 uW	161 mW
PSoC 5 (inactive)	2 uA	3.3 V	10.23 mW	294.6 mW

Overall, our power calculations are not a huge concern for this project because we have access to a large battery bank powered by solar cells. Our project runs off of a wall plug attached to this battery.

5 Firmware/ Software Design

5.1 Micro-controller Firmware

Our firmware for both of our devices is run on a combination of PSoC 4 and PSoC 5 micro-controllers. PSoC 4 was used for its compatibility with Bluetooth Low Energy in order to provide an interface with our smart phone app. PSoC 5 was used in order for its simple interface with our SD cards.

5.2 Environmental Monitor Firmware

The firmware state diagram for our Environmental Monitor is very simple. Every ten minutes a new measurement is taken from each of the sensors. This is then made available to the phone app over Bluetooth Low Energy and saved onto an SD card for permanent storage.

have an active Bluetooth connection.

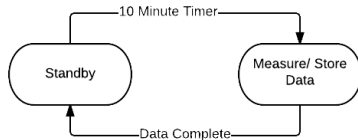

Figure 14:

5.3 Chicken Counter Firmware

Our firmware state machine for our chicken counter is fairly straight forward. Our device stays in standby mode until it encounters the first of two infrared trips. After it receives that trip, it waits until it receives the information from the RFID reader, and then the second infrared trip. From the two infrared trips, it can determine the direction the chicken is walking in and from the RFID reader it can determine the identity of the chicken. If a time period passes and not all of these events have happened in sequences, the data is discarded and the devices moves back into standby mode.

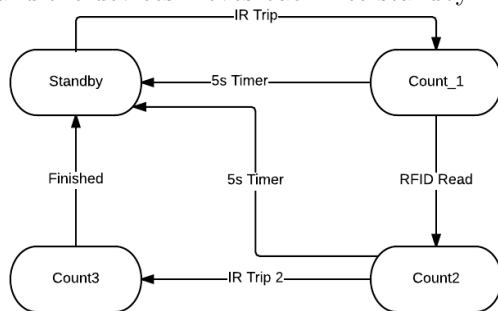

Figure 15: Chicken State Machine

5.4 App Software

Smart phones are becoming the default devices for information consumption and some farmers are taking advantage of this opportunity by introducing mobile applications that relay valuable information. This mobile application prototype is available for Android. The device must

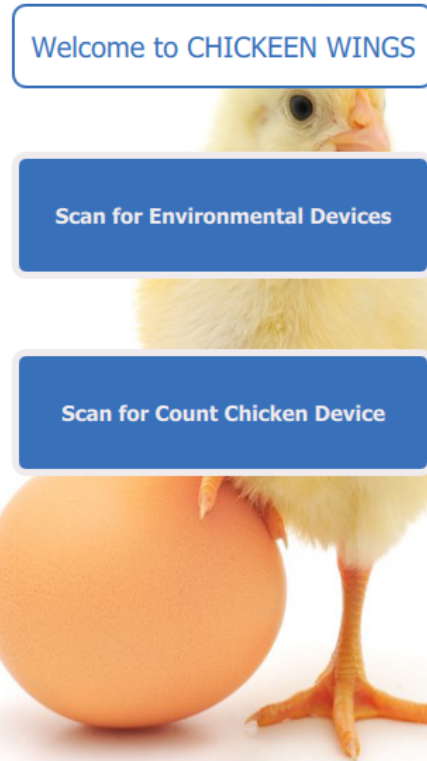

Figure 16: Main

(Figure 16) is the home page that opens when the application is started. At this screen, the user is able to access and use the main functionality of the application. There are two buttons on this page, which is "Scan for Environmental Devices" as well as "Scan for Count Chicken Device". In this screen, the user can select the device that they want. The background image is a chick with an egg and is used throughout the whole application.

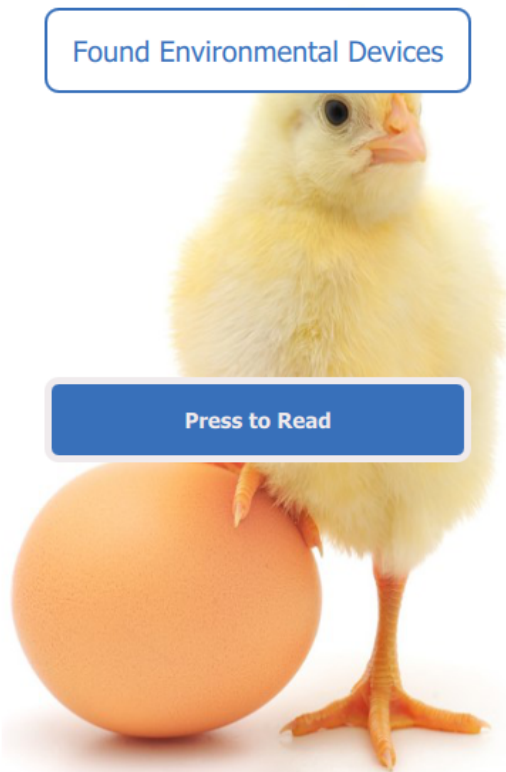

Figure 17: Read



Figure 18: Data

Selecting the device tab will bring up an "Data" screen, it shows the current temperature, humidity, light as well as the total of egg layer for that day. (Figure 19). The bottom tab, signified by the back label. This tab will bring the user back to the home page.

6 Procedure: Design Verification and Testing Methodology

6.1 Environmental Monitor

Our Environmental Monitor was tested through putting it through various environmental conditions and checking the temperature, humidity, and light levels that the sensors were recording on the SD card and making available over bluetooth to our phone. In order to test the light sensor, the device was tested the device at various light levels, including ambient room light, covering the sensor so that there was no light, and shining a flashlight on it. In addition, the device was ran at night and in the sunlight.

This tab, which is figure 10, is currently the default active tab when the user is directed to the "Press to read" screen (Figure 17). Those screens are a bit simpler in style, compared to the main screen, as they only have one list in the screen consisting of the different venues under that type.

Through this method, it was verified that the sensor was reading different levels of light that corresponded to the level of light the sensor had been experiencing. In order to test the temperature sensor, one could place their finger on the sensor which showed the temperature immediately begin to go up because my finger was hotter than the ambient environment. In addition, ambient readings were able to be checked with the actual temperature. A similar procedure allowed the humidity sensor to be verified. Placing a finger on the device allowed the humidity levels to increase. The device was field tested by allowing it to run over the course of a day, with the data being collected on the SD card and analyzed through a MATLAB script.

6.2 Chicken Counter

Our chicken counter was tested and verified by setting up the system on a wooden frame that was an analog to the chicken coop entrance. Our tags were then placed on an analog of the chicken in order to make sure that the counter could count the tags as they walked into and out of our coop. Through this, it could be verified from the SD card data that the correct chickens were being recorded as well as whether they were walking in or out of the coop. This helped us to reform and issue we were having with our timer when it would sometimes clear our data at inappropriate times. In addition, we field tested the system at the coop and it worked, so long as we made sure the chicken stepped on the RFID module. The main problem that we discovered about our system is that the range for our RFID was too small to cover the entire doorway. In order to improve our system, we would need readers and tags that have a longer range, or more readers in order to cover the entire doorway. As it turns out, 125 kHz tags are primarily meant for short range applications, which made our product less effective in the field.

7 Final Budget

After calculating a rough estimate of the project budget, including design materials, board ordering cost and hardware components, the materials needed for construction of the prototype would have a total cost of \$468.84. If this prototype were produced on a commercial scale, the unit cost would be dramatically reduced from

the prototype cost. Concerning the direct costs and starting from the system implementation needs, we prepared some information regarding the hardware and software tools we have used. The hardware components were used to build up the backbone of the system. We developed the software part. Table 36 shows the budget for the prototype.

	Price	Total Parts (prototype)	Total Cost (prototype)
Board Standoffs	\$2.95	5	\$14.75
Enclosure	\$9.95	2	\$19.90
PSOC 4 BLE	\$6.53	2	\$13.06
PSoC 5	\$6.86	2	\$13.72
Humidity Sensor #2	\$7.62	1	\$7.62
Antenna	\$0.93	2	\$1.86
Crystal 32.768 KHz	\$0.61	4	\$2.44
Crystal 24 MHz	\$0.76	2	\$1.52
Voltage Regulator	\$0.88	1	\$0.88
Charge Manager	\$0.60	1	\$0.60
USB Connector	\$2.28	1	\$2.28
Resistors	\$1.90	1	\$1.90
Capacitors	\$7.70	1	\$7.70
Light Sensor	\$1.33	1	\$1.33
IR Reciever	\$1.27	2	\$2.54
IR LED	\$0.65	2	\$1.30
NMOS MOSFET	\$1.15	2	\$2.30
SD Card Connector	\$1.20	1	\$1.20
3.7V, 1200mAh LiPo	\$9.95	1	\$9.95
Power Inductor (2.2 uH)	\$1.31	1	\$1.31
RFID Kit	\$49.95	2	\$99.90
Stackable Headers	\$0.50	5	\$2.50
RJ45 Connector	\$1.50	9	\$13.50
Cat6 Male Connector	\$6.38	5	\$31.90
SD Card	\$14.00	2	\$28.00
Charger	\$13.38	1	\$13.38
PCB Boards	\$91.50	1	\$91.50
Encloser	\$80.00	1	\$80.00
		Total	\$468.84

Figure 19: Budget

8 Results and Discussion

We installed our counting system into the UC Davis mobile chicken coop for 48 hours. After setting up the systems, we attached the EM4305 RFID tags to some of the chickens and let them pass through the entryway. In **Figure20**, you can see the data captured by our system on the SD card. While the system does work, it was clear that the short range of the RFID reader would present an issue for long term deployment. To fix this issue, we would have to move to a higher frequency tag and reader combination, as the industry standard of 125KHz has a short range. If there was a very good reason to stick with 125KHz, we would have to implement an array of antennas to completely cover the area that the chickens walk through. The casing also took quite a beating. While all of the electron-

ics survived, it is unlikely they would last very long in a serious deployment. One way to fix this would be to use an epoxy to completely seal the PCBs in, but we didn't do that for this test because that would make it near impossible to recover the boards if we wanted them for some reason.

Also, the area that the chickens walk through was not quite what we expected. It turned out that there were actually two paths a chicken could take once it got inside, which made it slightly more complicated to decide where to place the IR trips, and made it clear that multiple trips would greatly increase the reliability and accuracy of the system.

In software, we would want to adjust the way we decide if a chicken activated a trip, but not entered the coop. Currently we use a timer that decides nothing has happened if both trips don't go off within a certain amount of time, but after observing their behavior entering and exiting the coop, we would have to make a more rigorous checking system.

We also tested the range that Infrared could be received by our receiver from our transmitter. This range was about two feet which was greater than the 18 inches that we needed in order to cover the entire entrance way to the chicken coop.

```
# Chickens in Coop: 01 id: 8AE660 IN Date: 00/00/00 00:50:43
# Chickens in Coop: 02 id: 8AE660 IN Date: 00/00/00 00:50:46
# Chickens in Coop: 03 id: 8AE660 IN Date: 00/00/00 00:50:49
# Chickens in Coop: 04 id: 751B62 IN Date: 00/00/00 00:51:27
# Chickens in Coop: 03 id: 751B62 OUT Date: 00/00/00 00:52:34
# Chickens in Coop: 02 id: 8AE660 OUT Date: 00/00/00 00:52:50
# Chickens in Coop: 03 id: 8AE660 IN Date: 00/00/00 00:53:07
# Chickens in Coop: 04 id: 8AE660 IN Date: 00/00/00 00:53:29
# Chickens in Coop: 05 id: 8AE660 IN Date: 00/00/00 00:53:35
# Chickens in Coop: 04 id: 8AE660 OUT Date: 00/00/00 00:53:41
# Chickens in Coop: 05 id: 8552DB IN Date: 00/00/00 00:54:31
# Chickens in Coop: 04 id: C7FE35 OUT Date: 00/00/00 00:56:56
```

Figure 20: Data captured from live test

In addition, we ran our environmental monitor over the course of a 12 hour period to check that it could monitor the temperature, light, and humidity in its environment over that time period. During that time, it produced results that represented the time of day as well as the environment that it was in. The plots of the temperature, light, and humidity are listed below.

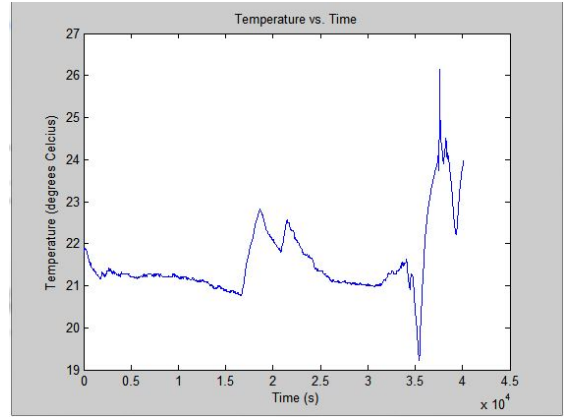

Figure 21: Data captured from live test of temperature

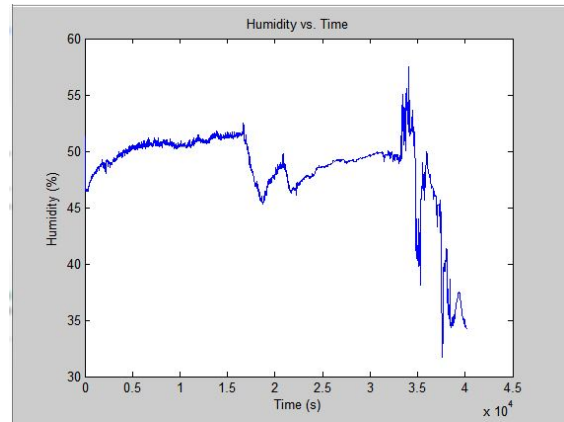

Figure 22: Data captured from live test of humidity

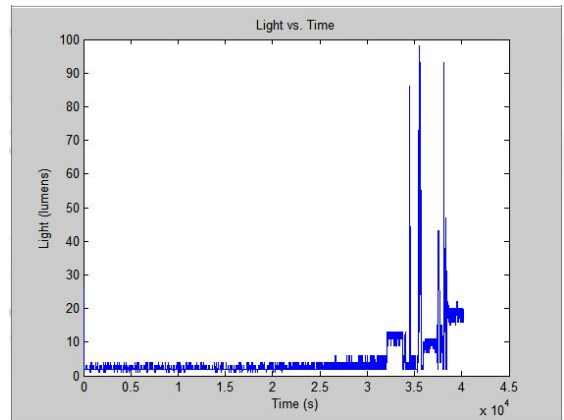

Figure 23: Data captured from live test of light

9 Conclusion

Our project was able to implement both the environmental monitor and chicken counter parts of our project. Our environmental tracker has

been shown to be able to successfully measure the humidity, temperature, and light of the environment and allow it to be shown elsewhere. This device could be used in many applications beyond a chicken coop in order to monitor the ambient environmental conditions. In addition, our chicken counter can be used to track chickens as they walk past and keep track of both the ID of the chicken moving in and out of the coop, as well as the total number of chickens moving in and out of the coop. Improvements to the chicken counter hardware could be made for a more reliable system in the future.

10 Acknowledgments

Our group would like to thank and acknowledge Both Cypress and Texas Instruments for both

their support in our project and their exceptional products that we used to complete our project. Also thanks to Brianna Myers for providing Latex support.

